

Specification

Model number : IB-102Q4

Product name : Interactive whiteboard

- Intelligent Pen-tray**
- Wireless Receiver**

1. Item Specifications:

1.1 Interactive White Board

No	Items	Specification
1	Technology	infrared
2	Diagonal size	2546mm (100 inch)
3	Resolution(max)	32768×32768
4	Respond Speed	first dot (click): 25 ms; Continuous dots (write) : 8 ms
5	Cursor Speed	100 dot/s
6	Positioning Accuracy	<1 mm
4	Display ratio	16:9
5	Active size	2224*1233 mm (100.3 inch)
6	Outside size	2270*1279 mm (102.6 inch)
7	Points support	10 points
8	Board material	E3 Ceramics surface materials, Cold rolled steel at back support, anti-damage, can be written with water pen and erase
9	Intelligent Pen tray	800*76.5 mm
10	Power	USB supply directly, <100 mA
11	Connect port	USB 2.0, USB 1.1 & USB 3.0
12	OS system	Windows 10, WinXP, Windows Vista / Windows7, Linux, MAC, Android
13	Driver	No
14	Temperature	Work: -10 °C to 45 °C; Storage: -30 °C to 60 °C
15	Humidity	Work: 0%~90% ; Storage: 0%~95%

1.2 Wireless Set

1.2.1	USB2.4TX Wireless Sender	
1.2.1.1	Input voltage:	DC : 9V 1000mA
1.2.1.2	Power Supply	Power adaptor
1.2.1.3	Current	Working : 60mA ; Maximum <500mA
1.2.1.4	Work Temperature	-20 °C to 85 °C;
1.2.1.5	Frequency Range	2400MHZ~2483MHZ
1.2.1.6	Transmitted Power	3dbm
1.2.1.7	Output voltage	DC 5V
1.2.2	USB2.4RX Wireless receiver	
1.2.2.1	Input voltage:	5V
1.2.2.2	Power Supply	Supply by Laptop or PC
1.2.2.3	Current	50mA
1.2.2.4	Work Temperature	-20 °C to 85 °C;
1.2.2.5	Frequency Range	2400MHZ~2483MHZ
1.2.2.6	Sensitivity	-91db

2. Brief Software functions:

#	Function name	Description
---	---------------	-------------

1	Writing	Can be done by pen, pencil, highlight pen, laser pen, soft pen, etc
2	Intelligent pen	Intelligent pen can fix and recognize the drawing lines into standard straight line, broken line, rectangle, oval, circle
3	Transparent page	Writing and mouse function seamless handover, user can write and control the computer at the same time
4	Magic eraser	Dot and line cleaning, defined area cleaning and whole page cleaning, multi choices
5	Word note	Insert handwriting into the office files and save as the same format of ordinal file
6	Multi model support	User can choose different model of software, windows, desktop, full screen and frame model
7	Multi touch	2 or more users at the same time, fluently operation of the whiteboard
8	Float toolbar	Special toolbar float on the software surface, easy to chose function button and move, hide the toolbar
9	Recorder	Instant recording of all operation of the software, save as AVI format, user can open it at anytime if needed
10	Compatible function	Support different format courseware, such as words, image, flash, AV, PPT
11	Various page format	User can create different color page, current page, desktop page, transparent page, image page, customize page, also color can be changed
13	Screen cover	Cover parts of the screen, point out the important content
17	Teaching texture page	Teaching texture page
18	Page roaming	Move the page freely, unlimited page size
20	Customize menu	User can customize float menu, this allows users to operate more convenient
21	Customize data sheet	User can set the user, toolbar and other data sheet.
22	Screen lock	User can lock the screen if needed
23	Handwriting recognition	Support serial language words, sentence recognition, finger gesture recognition special function, e.g. insert, delete.

3. Certification:

#	Name	Description
---	------	-------------

1	Copy right	Drawview copyright
2	Reliability test report	Tests report approved by national Inspection Institution
3	Quality system	ISO9001, ISO14001, CE
4	Environment	RoHS, REACH

4. Cables:

connect cable (USB)

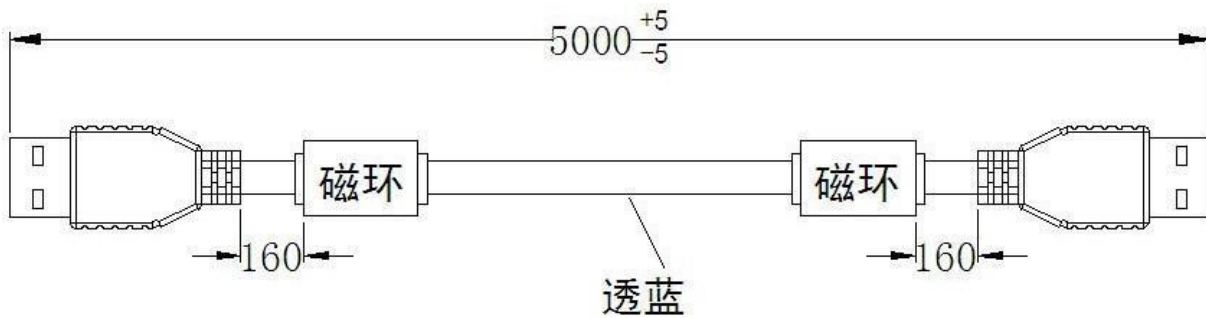

5. Every set contains:

Item	Specification	Quantity	Remark
Interactive whiteboard	102"	1pc	
USB cable	5M	1pc	
Intelligent pen	blue/red /black/yellow	1 set (4pcs in different color cover)	
pointer	D8*1000 mm 6 section	1pc	

Wireless sender	White:mini USB Port / DC 9V port /	1pc	
Wireless receiver	USB	1pc	
Wireless adaptor	1M	1pc	
Wall mount	1 set	1 set	

View of pen

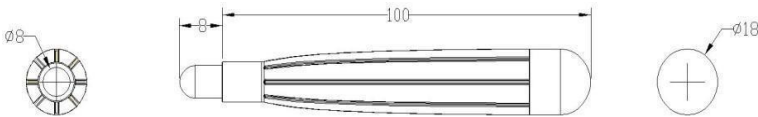

View of an Interactive Whiteboard

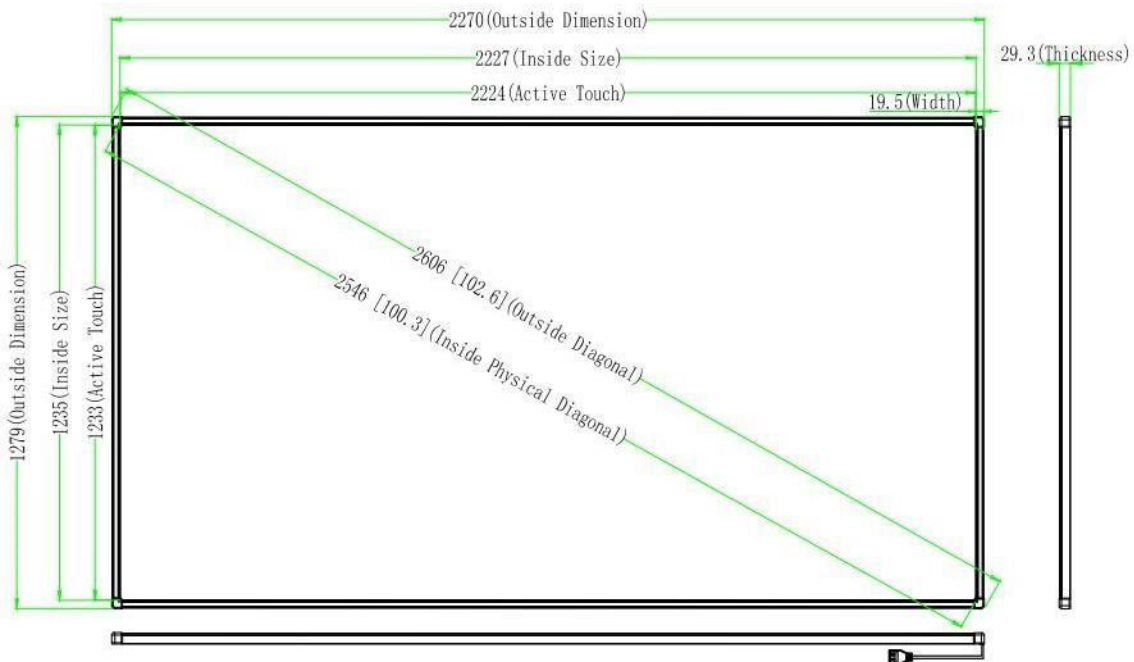

View of an Intelligent Pen-tray(for reference only)



View of an Wireless Devices



SUPPORT DE TAVAN SI PERETE PENTRU VIDEOPROIECTOR

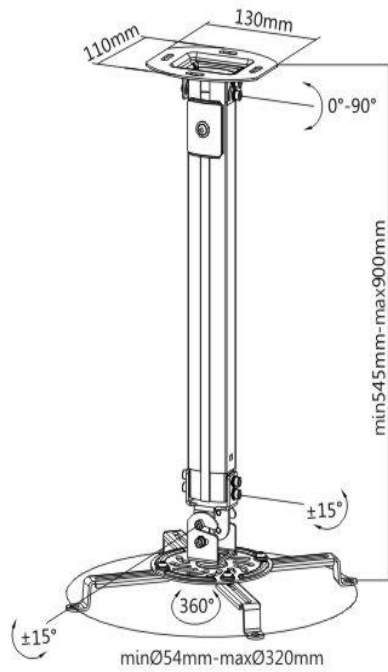

CARACTERISTICI:

PRB-18M este un suport universal de tavan si perete pentru proiectoare de până la 13,5 kg. Placă înclinată pentru aplicarea pe tavan sau perete. Oferă poziționare multidirecțională cu patru brațe de sprijin reglabile care se pot potrivi cu o gamă largă de videoproiectoare. Conectorul cu eliberare rapidă permite instalarea rapidă a proiectorului și apoi eliberarea cu ușurință pentru întreținere, fără a necesita realiniere. Coloana retractabilă din aluminiu oferă reglarea înălțimii pentru diferitele opțiuni. Acest suport pentru proiector este perfect pentru utilizarea în săli de clasă, săli de conferințe, hoteluri, baruri și restaurante sau oriunde trebuie montat un proiector.

SPECIFICATII TEHNICE:

Material	Otel si aluminiu
Finisaj de suprafata	Vopsea electrostatica cu pulbere
Culoare	Alb mat / Negru mat
Dimensiune	334 x 334 x 900 mm
Greutate maxima	13.5 Kg
Interval reglare	54~320 mm
Gama de inclinare	+15°~-15°
Gama de pivotare	+15°~-15°
Rotatie	360°
Gama de extindere	545~900 mm
Instalare	Tavan
Suport management cabluri	Da
Certificari	UL

Portable Projector

Vivitek DW275

WXGA projector with a brilliant image, multiple I/O ports and long-life lamp



Features

- Up to 4,000 lumens with a strong contrast ratio
- Native WXGA resolution with a maximum WUXGA resolution
- DLP® and BrilliantColor™ technologies for distinct and vibrant images
- Low cost of ownership and maintenance with an energy efficient lamp for up to 10,000 hours (Dynamic Eco. Mode) of usage
- 6 segment (RGBYCW) color wheel for improved and vivid color reproduction
- Manual zoom and focus for easy adjustment and positioning flexibility
- Full suite of display connectivity inputs and outputs
- 2W of total stereo audio power with multiple audio-in and audio-out ports
- Choose from 8 pre-set display modes to get the most suitable display image
- Top sided lamp cover for simple lamp removal and insertion
- Intuitive multiple language OSD (On-screen Display) menu
- Environmentally friendly with less than 0.5W of power in stand-by mode
- Portable and lightweight at only 2.6kg (5.7lbs)
- Anti-theft security features include: Kensington® security slot, and security bar

Specifications

Display Type	Single Chip 0.65" DLP Technology by TI
Brightness	4,000 Lumens
Native Resolution	WXGA (1280 x 800)
Maximum Resolution	WUXGA (1,920 x 1,200)
Contrast Ratio	20,000:1
Lamp Life/Type	5,500/7,000/10,000 Hours (Normal/Eco./Dynamic Eco. Mode), 210W
Throw Ratio	1.55 - 1.86
Image Size (Diagonal)	40" - 300"
Projection Distance	1.3m -10.2m (4.3ft - 33.5ft)
Projection Lens	F=2.42 – 2.62, f=22.5 – 25.79mm
Zoom Ratio	1.2x
Aspect Ratio	16:10
Offset	104%±5%
Keystone Correction	Vertical:±40°
Horizontal Frequency	15 -102kHz
Vertical Frequency	23 - 120Hz
3D Compatibility	Yes
Speaker	2W (Mono)
Computer Compatibility	VGA (640 x 480) to WUXGA_RB(1920 x 1200)
Video Compatibility	NTSC, PAL, SECAM / 480i, 480p, 576i, 576p, 720p, 1080i, 1080p
I/O Connection Ports	HDMI v1.4b (x2) (HDCP v1.4 Compliant), Composite Video, S-Video, VGA-In (x2), Audio-In (Mini-Jack), VGA-Out, Audio-Out (Mini-Jack), RS232, USB (Service)
Projection Method	Table Top, Ceiling Mount (Front or Rear)
Security Solutions	Kensington® Security Slot, Keypad Lock
Dimensions (WxDxH)	332 x 244 x 105mm (13" x 9.6" x 4.1")
Weight	2.6kg (5.7lbs)
Available Colors	White
Noise Level	32dB/29dB (Normal/Eco. Mode)
Power Supply	AC 100-240V, 50/60Hz
Power Consumption	250W (Normal Mode), 210W (Eco. Mode), <0.5W (Standby Mode)
Standard Accessories	AC Power Cord, VGA Cable, Remote Control, Documentation Kit
Optional Accessories	Lamp

©2020 Vivitek. Vivitek is a trademark of Delta Electronics, Inc. Other trademarks are the properties of their respective owners. Values, weights and dimensions shown are approximate. Errors and omissions accepted. Specifications are subject to change without prior notice.



Photos

